



In This Issue

- Presidents Corner 1
- Wheel Pants 2
- In the Right Seat 3
- EAA 62 Member Profile 4
- Special Events 5
- Flying Gourmets 6
- Around the Patch 6
- Celebration of Unity 7

Calendar of Events

Thursday, April 3

Chapter Meeting

6:30pm – Hangar Flying, with Hot Dog dinner.

7:30pm - Meeting

Guest Speaker: Max Rescott, Master CFI - Student to ATP and everything in between.

Saturday, Apr 19

Show 'n Tell in Morgan Hill

11 AM to 1 PM. Tony Babb is building a Velocity in his garage. Directions and more info in the April Newsletter. Limited parking, so suggest carpooling.

Saturday, Apr 26

Fly-out to Columbia

Rain will cancel this event. We will meet at the Columbia Airport, inside the small terminal building, at 10:50 AM and walk over to Aero Resource for a presentation on PREVENTING

Where Do We Meet

Victory Aviation
2502 John Montgomery Drive
Reid Hillview Airport
San Jose, CA 95148

President's Corner

By Andy Werback

Many thanks to Terri Gorman for filling in for me at the last meeting. I was off with Gregg Victory in his newly updated red Yak-52 to Deer Valley Airport, just north of Phoenix. There's nothing like 5 hours of cross-country while sitting on a parachute seat pack. We got there just after sunset, and everything in the Yak worked pretty well, including the EFIS, panel and other updates. I got a little back seat formation time with the Red Star Yak guys, then back to San Jose (yes, 5 more hours).



Welcome to our visitors Rod Pharris (another Lancair Guy), and Jim Meide, whom most of us know. Thanks very much for visiting, hope to have you back any time you can make it.

Also, many thanks to Martin Hollman for his presentation on homebuilding aircraft and the materials being used for construction.

By now you're all pretty aware of the Santa Clara Board of Supervisors project to explore closing RHV. At this time, it's an exploratory task, but already a lot of folks are getting organized. I urge you to participate in the RHV Airport Association and CRAMP activities as a way of making your voice heard. You can also write to the Supervisors and to your San Jose city officials. San Jose has a significant vested interest in what happens at Reid Hillview. We've already received great support from the FAA and AOPA opposing any change to the status of RHV.

Young Eagles events are about to start. If you haven't been doing so already, you might want to save your aviation magazines, charts and anything else that might be useful to someone else. We would like to give these away at the YE events.



Other than that, the fly-in and airshow event schedule is starting to open up. Good weather is here... I think... so get out there and exercise your skills. Last weekend was especially nice, and we got in a cross country up to Medford and back.

Andy

Calendar of Events

(continued)

Fly-out to Columbia (cont.)

CORROSION IN AIRCRAFT and a barbeque following. We will have a chapter campout and/or for those of you who prefer the comfort of a bed, I can provide a list of motels in the area. Terri at 408-828-6707 or flyrhv at aol.com .

Sunday, April 27

Half Moon Bay: Dream Machines

Pacific Coast Dream Machines Fly-in and Show. 10am to 4pm. KHAf, details (650) 726-2328.

Tuesday, April, 29

Flying Gourmets at Tracy

Brown Bag Lunch, noon at Tracy Airport (KTCY).

We will swap lunches in the picnic area at the Tracy Airport. Each person in the plane brings a brown bag lunch. Vegetarian lunches should be marked with a V on the outside. Drinks available.

Tracy Airport always has good prices on aviation fuel.

Terri at 408-828-6707 or flyrhv at aol.com

Upcoming Speakers

June 2008

RHV Controller - Flying in controlled airspace.

July 2008

Shawn Kelly, CFI - Owning and flying a Light Sport Aircraft

August 2008

Tales for Oshkosh

September 2008

Dave Saylor of Aircrafters - Homebuilding

October 2008

Jeff Lo - Reno Air Races

November 2008

Jessica Panzee - Air Show Performer and Corporate Pilot

Ideas on Wheel Pants

By Bob Kindlund

When I walk around Reid-Hillview, I see fixed gear aircraft with and without wheel pants and I've wondered what the difference in performance is. On some high performance aircraft, we neatly tuck the gear up into the wing or fuselage to gain higher speeds. On new designs, such as Cirrus or Lanciar, are aircraft that have fixed gear and are attaining speeds equal to or greater than aircraft with retractable gear. But even these new designs still have a portion of the tire sticking out of the bottom of the fairing. What if we could have doors that covered the exposed portion of the tire while in flight, would that make an improvement in performance?

In 1971, Jim Bede received a patent (U.S. patent number 3,750,986) for wheel pants (fairings) that included doors on the bottom that would cover the wheels while the aircraft was in flight. When taxiing, landing or taking off, the doors would be open to allow the wheels to make contact with the ground. The doors could be operated mechanically, electrically, hydraulically or pneumatically. On the BD-4, a push-pull cable from the cockpit operates the doors.



In the patent, he states that with the tire exposed at the bottom of the fairing, the fairing creates a cavity into which air can enter and cause drag and vibration. With the tire covered and the fairing properly designed, aerodynamically, there could be significant improvements in reducing drag. He states that in actual tests, aircraft using this invention have an increase in airspeed of approximately 10%.



In 2006, Clifford Cordy received a patent (U.S. patent number 7,108,225) for an improved version of the Bede patent. Basically, Mr. Cordy refines the shape of the fairing, as shown in his figures, to give a more

aerodynamic profile and thus reduce drag.

Both of these patents cover ideas and designs that could bring improvement in performance to GA aircraft. But to gain this improvement, there is added complexity and cost to parts of the aircraft and these costs are not detailed in the patents. If you would like to read these patents in detail, they are available on-line at the U.S. Patent and Trade Mark Office, www.uspto.gov.

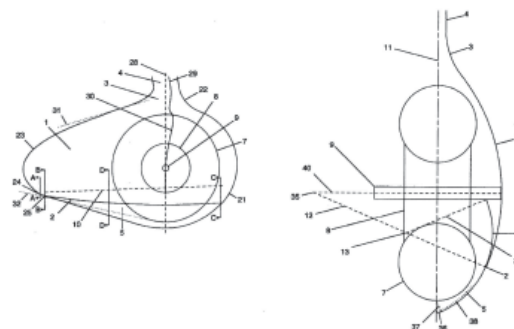

In The Right Seat

By Terri Gorman

Max Trescott will be our Guest Speaker at our April Meeting. Recently, Max was selected as the 2008 National Certificated Flight Instructor of the Year by the General Aviation Awards Program, an award presented to the best flight instructor. Max is very passionate about aviation. I first met Max at Reid Hillview Airport about four years ago. I had heard him speak and suggested that he contact EAA National and



be a speaker at one of their forums. The next time I saw Max, he was speaking in a forum I was attending at Air Venture. Along with authoring and publishing three books on the Garmin Glass Cockpit, Max is a flight instructor at the Palo Alto Airport and manages to keep himself fully immersed in aviation. He will speak on Student to ATP and everything in between. Bring your questions and

expect a very entertaining evening.

After listening to Martin Hollmann speak at our March meeting, we visited him at his business, Aircraft Design, in Monterey. Three pilots flew down with a total of five passengers and 15 members and guests drove down.



Martin designed and built the Stallion in 18 months. The Stallion, a composite aircraft, can fly from California to Boston without stopping for fuel. Martin, also, teaches classes on Flutter, Design and Composite Builders Workshops.

After visiting with Martin at his office for over an hour, we carpooled down to the Monterey Wharf for lunch. There were 23 members and guests. One couple were from British Columbia. (I didn't know our chapter was so well known!!) Their interests

Chapter 62 Contacts

Andy Werback, President

(408) 262-8622
andyw54_punt@earthlink.com

Terri Gorman, Vice President

(408) 828-6707
flyrhv@aol.com

Terri Gorman, Secretary

(408) 828-6707
flyrhv@aol.com

Randy Wilde, Treasurer

(650) 968-3048
randallwilde@mac.com

Wolfgang Polak, Website

(408) 735-8014
webmaster@eaa62.org

Jeff West, Young Eagles

(408) 314-7436 - Cell

Rolland LaPelle, Flight Advisor

(925) 939-0472
CFI/CFII & SMEL
rlapelle@astound.net

Tech Counselors

Engineering & Design

Martin Hollman
(831) 621-8760
jets@mbay.net

General Topics

Rolland Lapelle, A & P IA
(925) 939-0472
rlapelle@sbcglobal.net

Mechanical

Brian Dal Porto
(408) 802-7040

Board of Directors

Jack Bowlus

(831) 637-1137

Allen Roark

(408) 926-1711

Ron Carmichael

(408) 772-7745

Wolfgang Polak

(408) 735-8014

Board of Directors (continued)

Jeff West

(408) 314-7436 - Cell

Rusty Wells

(408) 243-9053

Past President

Terri Gorman
(408) 828-6707

Newsletter Editor

Bob Kindlund
(408) 726-3912

Programs

Terri Gorman
(408) 828-6707

Membership

Roger Kopp
(408) 255-7009

Shop & Swap — OPEN

In The Right Seat *(continued)*

were in homebuilding. The pilot had built a Mustang and was working on another homebuilt.

Arriving at the Monterey Airport after lunch, the ceilings were low, so Gary Niva, along with his three passengers, rented a car and drove back to San Jose. Bob and I drove Tom Diede and his passenger back to Reid Hillview. The rest of the visitors and guests found seats in available cars for their trip back to San Jose. Jeff West, our Young Eagles Coordinator, decided since he had a rental plane out of Amelia Reid Aviation, the first thing he had to do was call the school. (I'm sure the first thing he did was call his wife.) He had a brother that lived in Marina, so he wasn't too concerned about hitching a ride in a car. Luckily for him, he waited out the low ceilings and was able to do his first Special VFR Departure. Meanwhile, the owner of Amelia Reid Aviation was enroute with a student and another CFII to pick up the Cessna. Everyone had a good time and this was our largest group for any fly-drive adventure. Martin Hollmann is an excellent host and always welcomes us for a visit.



Tom Diede's RV8 spent the night at Monterey



Gary Niva (stepping onto his Bonanza) and passengers returned from the run up area

Martin Hollmann offered accommodations in his sail boat. Gary Niva had the Aero Dinner to attend at Hiller Museum and arrived there one minute before dinner was served.

EAA Chapter 62 Member Profile

By Terri Gorman

Wolfgang Polak takes center stage this month as my Chapter 62 VIP. If you ever need to know what's going on within our chapter and/or any other destination as far as aviation events, look no further than our Award



Winning Website, www.eaa62.org, of which Wolfgang, as our Webmaster, keeps very up-to-date.

Wolfgang has been a member of EAA Chapter 62 and on the Board of Directors for many years. He currently owns and flies a Grumman Tiger which he has tied down at the Palo Alto Airport. He has been very active with the Young Eagles Program as a pilot, and more recently, he has been doing a lot of formation flying. Wolfgang says, if flying is like playing an instrument, formation flying is like playing in an orchestra and flying Lead is like being the Conductor.

Wolfgang got his license in 1977 at the Palo Alto Airport and racked up 2300 hours in C-SEL, P-SES, Instrument, Tailwheel, Complex, High Performance. (And if you can't figure out what all those letters stand for, you can ask Wolfgang!) He flew in the US, Canada, Australia and various areas in Southern Africa. He used to fly aerobatics, but he can't do that in his Grumman.

His hobbies include flying, running, cycling and swimming. He completed 79 marathons and used to do 100 mile races.

He met his wife, Gudrun, in college when they were both attending a seminar on Lattice Theory. He and Gudrun have no children. They live in Sunnyvale.

Wolfgang was born on March 8, 1950, same day as my good friend and chapter member Ken Wardrip, although Wolfgang was born a few years after Ken. He was born in a small town near Dresden, Germany, in what used to be referred to as East Germany.

His interest in aviation began when his father gave him a ride in a Cub at age 9 or 10. His Dad was flying Bf109s in the war. Flying in Germany was very expensive, so his Dad had to give it up. Wolfgang has a brother that is 13 years younger. His parents passed away a long time ago.

EAA Chapter 62 Member Profile

(continued)

As a child, Wolfgang was interested in 'what he calls' nerdy stuff and ham radio, used to be DK2BZ in Germany, but that has since expired.

For two years, Wolfgang was in the Military Service spending time in the German mud as a radio man in the army which he considered to be not fun.

Wolfgang attended school near Frankfurt, Germany. He received his MS Degree in Computer Science at the University of Karlsruhe in Germany in 1976 and his PhD in Computer Science at Stanford University in 1980. He, presently, works as a Consultant.

EAA Chapter 62 Special Events

Our April fly out will be to Columbia Airport on Saturday, April 26th. The owner of Aero Resources will give us a presentation on How To Prevent Corrosion in Airplanes. There will be a barbeque following the presentation. Columbia Airport has a campground for pilots-only. Plan to spend the night and/or book a motel. This is a cute, historic town with lots of things to see and do. Need a seat or share the seat, Terri at 408-828-6707.

On Saturday, April 19th, Chapter Member Tony Babb has invited us to his home in Morgan Hill for a Show n Tell from 11 AM to 1 PM. Tony is building a Velocity. Tony's address is 3135 Thomas Grade, Morgan Hill. 408-782-2012 11 AM to 1 PM

A Velocity is a 4-place composite airplane, Canard pusher, experimental.



Tower Tours

By Terri Gorman

Six chapter members toured the Control Tower at Reid Hillview Airport on Thursday, March 6th before our General Meeting. Jim Jensen, long time Controller, explained the happenings within the Tower. He asked me to give the ATIS Information over the microphone. It's a lot easier to repeat it than to read it off a card. I hope I didn't lose any pilots after that announcement! The Tower Tours will continue through October and are limited to EAA Chapter 62 members only. Attendees meet inside the Reid Hillview Terminal Building at 5:30 PM on the night of each monthly meeting. Contact Terri at 408-828-6707 or flyrhv@aol.com to be placed on the list. This is a one time visit only

Around the Patch

This artwork dedication in commemoration of flight pioneer John J. Montgomery was on display on March 15th at San Felipe and Yerba Buena Roads in San Jose. However, I found it on display inside the terminal building at Reid Hillview Airport.



Wing created by the Civil Air Patrol
Reid Hillview Airport

EAA Chapter 62 Flying Gourmets

Tuesday, April 29 Noon at the Tracy Airport BROWN BAG LUNCH

No taxes and/or tips to pay on this fly out luncheon. Bring a lunch in a bag and we will exchange lunches at the Tracy Airport. Drinks available. We will eat in the Picnic Area.

Low on fuel, TCY consistently has the best prices. Each person in the plane is asked to bring a Bag Lunch to exchange. Confused: Call Terri at 408-828-6707 or flyrhv@aol.com



March meeting Pictures



A Celebration of Unity – Everyone Invited

******Pig Roast******

Where: Hollister Airport – Large Hangar next to Gavilan College

When: Saturday, April 5th at Noon

Details: Meat and Beverages Provided – Side Dishes Appreciated!

Last Name A thru J - Side Dish

K thru P – Salad

Q thru Z – Desert

Contacts: Ruth Erickson 831-637-0987

Ed Owens – owens@razzolink.com

Come One – Come All
Fly In – Drive In – Whatever
Let's Celebrate!



AMELIA REID
AVIATION



2650 Robert Fowler Way
San Jose, CA 95148
Telephone 408.251.4939
Cell 408.891.4041
www.ameliareid.com

Flight Training • Tailwheel • Aerobatics

Zdravko Podolski
CFI, CFIII

Our web site www.eaa62.org donated by



HURRICANE ELECTRIC
INTERNET SERVICES



Brian Stout

Inspection Airframe/Engine

Hangar (408) 251-4942

Home (408) 482-3454

Cell (408) 882-4981

Aircraft Maintenance & Repair

13290 Kestrel Avenue

San Martin, CA 95046

Ship To: 2650 Robert Fowler Way Ste. 10, San Jose, CA 95148

Victory's Dynamic Propeller Balancing

Kregg Victory

Factory Certified Specialist
Airframe & Powerplant Mechanic

408-836-5122

email : kregg@balancemyprop.com
website: www.balancemyprop.com



San Jose, California

Send New & Renewal Memberships to:

Roger Kopp rgkopp@aol.com

11178 Sutherland Avenue

Cupertino, CA 95014

(408) 255-7009

Or to our website at www.eaa62.org

Chapter Membership - \$30.00 Annually

National EAA membership is required

Chapter dues can be paid on-line with PayPal

General Meeting: Thursday, April 3, 2008

Board Meeting: Thursday, April 10, 2008

April Speaker: Max Trescott, Master CFI - Student to ATP

Our meetings are open to the public. EAA members, their GUESTS, AND VISITORS ARE ALWAYS WELCOME. Chapter 62 usually meets on the 1st Thursday of each month (the 2nd Thursday in August), at 7:30 PM. at Victory Aviation, Reid Hillview Airport, 2502 John Montgomery Drive, San Jose, CA 95148.

Hangar Hour: Come meet your Fellow EAAer's, make new friends, have some food, and enjoy the camaraderie. Food will be sold from 6:30: to 7:25 during which time you can "hangar fly." The meeting will start promptly at 7:30 PM.

Roger Kopp
11178 Sutherland Avenue
Cupertino, CA 95014